

### Coordinated Ramp Metering for Freeways

Freeways were originally conceived to provide virtually unlimited mobility to road users, but the continuous increase in car ownership and demand has led to a steady increase (in space and time) of recurrent and nonrecurrent freeway congestion, particularly in and around metropolitan areas. Freeway congestion causes excessive delays, increases fuel consumption and environmental pollution, and deteriorates traffic safety.

Ramp metering, the most direct and efficient way to control freeway networks, aims at improving traffic conditions by appropriately regulating inflow from the on-ramps to the freeway mainstream. Coordinated ramp-metering strategies make use of measurements from a freeway network to control all metered ramps included therein. A new traffic-responsive feedback control strategy that coordinates local ramp-metering actions for freeway networks has been developed at the Dynamic Systems and Simulation Laboratory of the Technical University of Crete, Greece. The proposed coordination scheme is named HERO (heuristic ramp metering coordination) and has been extensively tested via simulation as well as in field implementations. The developers are the recipients of the 2010 IEEE CSS Transition to Practice Award, a prize awarded by the IEEE Control Systems Society to recognize outstanding university-industry collaboration that enables the transition of control and systems theory to practical industrial or commercial systems.



#### Solution Overview

HERO is simple and utterly reactive, that is, based on readily available real-time measurements, without the need for real-time model calculations or external disturbance prediction. HERO is modular in structure and includes many interacting and cooperating feedback control loops (such as mainstream occupancy control, ramp queue-length control, waiting time control), as well as two Kalman filters for estimation of ramp queue length and mainstream critical occupancy. Generic software has been developed that implements the HERO coordination scheme for any freeway network via suitable input configuration. Several extensions and improvements have been incorporated into the HERO system based on the experience gained from implementation, making it more efficient and generally applicable.

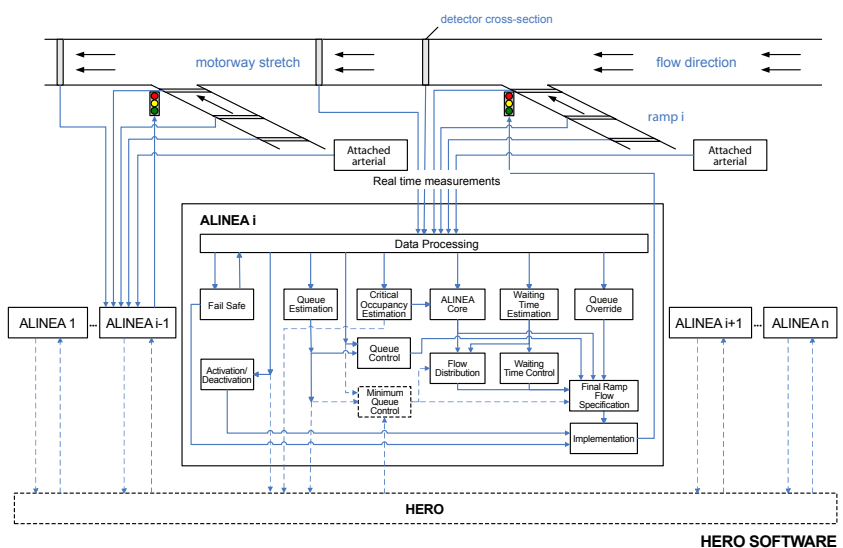

Modular structure of the HERO coordination software, including the ALINEA regulator for local ramp metering

Contributors: Markos Papageorgiou and Ioannis Papamichail, Technical University of Crete, Greece

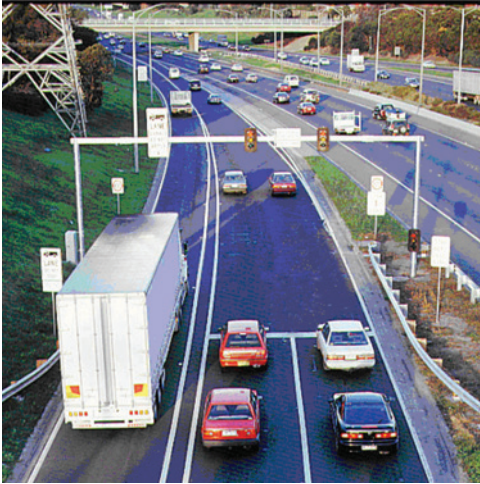

## Field Application at the Monash Freeway, Australia

Since 2000, Melbourne's freeways had become increasingly congested with extended periods of flow breakdown. The Monash Freeway, a six-lane dual carriageway that carries in excess of 160,000 vehicles per day, of which up to 20% are commercial vehicles, was experiencing long periods of congestion lasting between three and eight hours a day.

In early 2008, to address this problem, the responsible road authority, VicRoads, implemented HERO at six consecutive inbound on-ramps of the Monash Freeway. This \$1M (Australian) pilot project was part of the Monash-CityLink-West Gate (MCW) upgrade and received two 2009 Victorian Engineering Excellence Awards, one for Technology and one for Engineering Innovation. Significant benefits were demonstrated over the previous metering policy. The control logic has proven to be robust and transparent to traffic engineers. Transition to HERO has been seamless to motorists and has provided significant flexibility and capability to operate the freeway close to optimal conditions. The pilot project economic payback period was estimated at just 11 days. The successful implementation and evaluation of HERO led to its rollout during 2009–10 at 63 sites across the entire 75-km route of the MCW upgrade project; furthermore, 12 new sites of M80 and two new sites of M8 were added in 2012–13.

An evaluation of HERO's field performance was undertaken by VicRoads. HERO reduced the space-time extent of freeway traffic flow breakdown and provided significant improvements in throughput and travel speed. The a.m. peak evaluation revealed a 4.7% increase in average flow (over the previous system) and a 24.5% increase in average speed, whereas the p.m. peak evaluation showed an 8.4% increase in average flow and a 58.6% increase in average speed.

## Other Field Applications

In 2006, HERO was also implemented in a 20-km stretch of the inbound A6 freeway in the south of Paris, France, albeit in a preliminary and simplified form due to lack of real-time on-ramp data in the control center. Nevertheless, results indicated a clear improvement over the existing system. In 2011, HERO was deployed at six on-ramps along a section of the Pacific Motorway and South East Freeway (M1/M3) in Queensland, Australia. The successful implementation and evaluation of HERO led to its extension during 2012 to two more sites. Finally, HERO is currently being implemented in a North American freeway, and further implementations are in a planning or discussion phase.

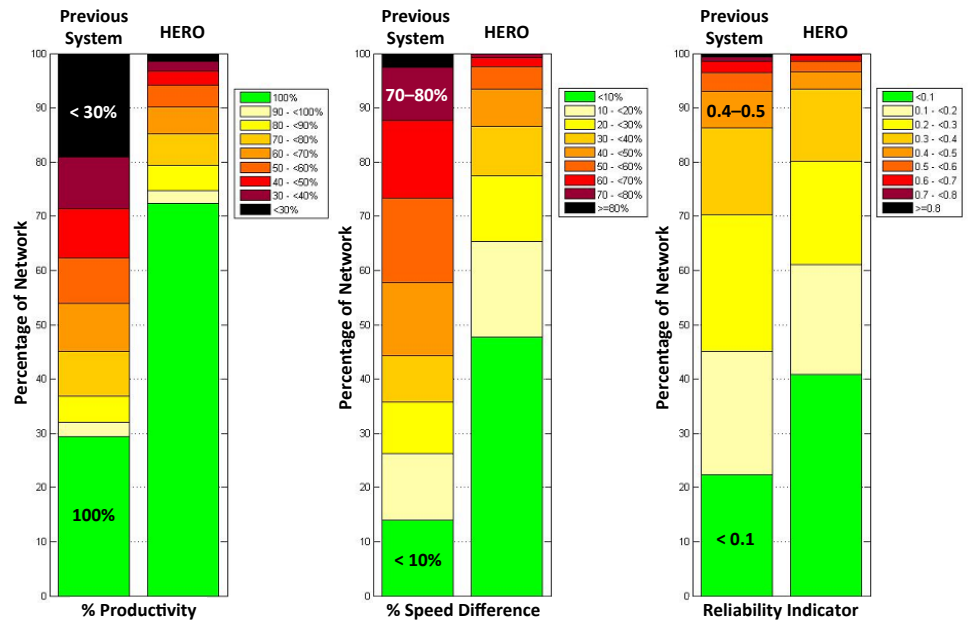

Results from the HERO implementation on the Monash Freeway using Austroads National Performance Indicators (ANPI). Three indicators are shown, with side-by-side before-and-after comparisons for each. Left to right, the indicators are: productivity (a combination of high speed and high volume on the freeway), mean speed deviation from the posted speed limit, and reliability (reflecting travel time differences from day to day). The green-to-black color codes reflect best-to-worst performance.

For more information: I. Papamichail and M. Papageorgiou, *Traffic-responsive linked ramp-metering control*, *IEEE Transactions on Intelligent Transportation Systems*, vol. 9, pp. 111–121, 2008; I. Papamichail et al., *Heuristic ramp-metering coordination strategy implemented at Monash Freeway, Australia*, *Transportation Research Record, Journal of the Transportation Research Board*, no. 2178, pp. 10–20, 2010.